

**HD™ Heavy Duty Conveyor Printers for varying surfaces and bulging shapes. Precisely located as well as continuous printing. Color or type changes in seconds. Exceptionally rugged design is ideal in virtually any case coding application. Ideal for date, batch, or logo printing on most moving surfaces.**

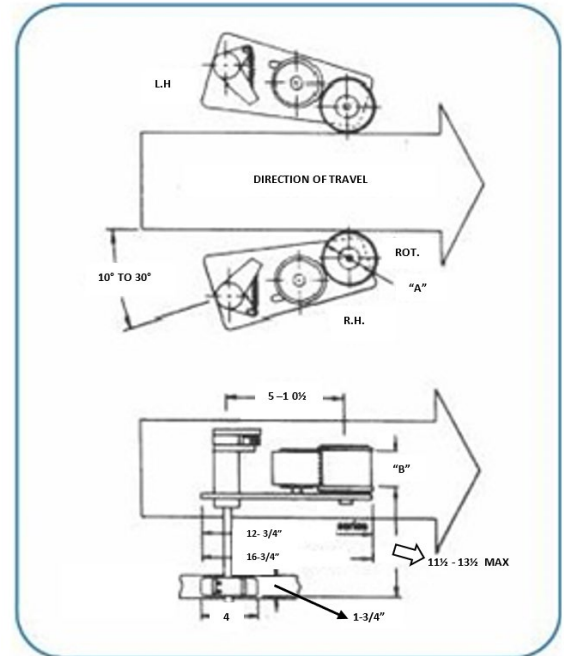
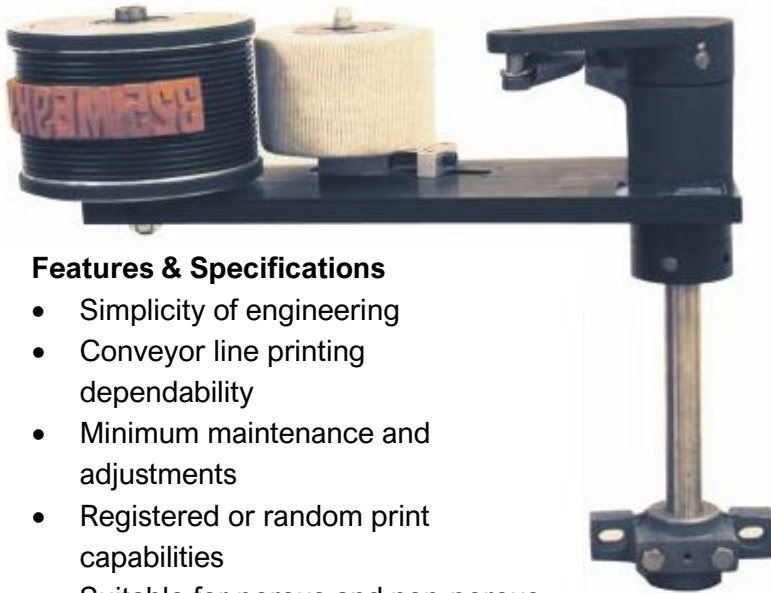

### Features & Specifications

- Simplicity of engineering
- Conveyor line printing dependability
- Minimum maintenance and adjustments
- Registered or random print capabilities
- Suitable for porous and non-porous

MODEL #	HD 32/32P	HD 33/33P	HD 34/34P	HD 42/42P	HD 43/43P	HD 44/44P
Diameter of "A" Print Wheel	4-13/16" (12.2cm)	4-13/16" (12.2cm)	4-13-16" (12.2cm)	5-13/16" (14.8cm)	5-13/16" (14.8cm)	5-13/16" (14.8cm)
Max Repeat Length of Imprint	15" (38.1cm)	15" (38.1cm)	15" (38.1cm)	18" (45.7cm)	18" (45.7cm)	18" (45.7cm)
Max Imprint Height "B" of Imprint	7/8" (2.2cm)	2-1/8" (5.4cm)	3-7/8" (9.8cm)	7/8" (2.2cm)	2-1/8" (5.4cm)	3-7/8" (9.8cm)



Units are available with interchangeable Perma-Grip® rubber type in Regular or Deep Depth™ or rubber die-sleeves for special arrangements and design. Many sizes and combinations are available for these imprinters. Please see the Perma-Grip® type sheet for exact information.